

**152 01 02 22222**

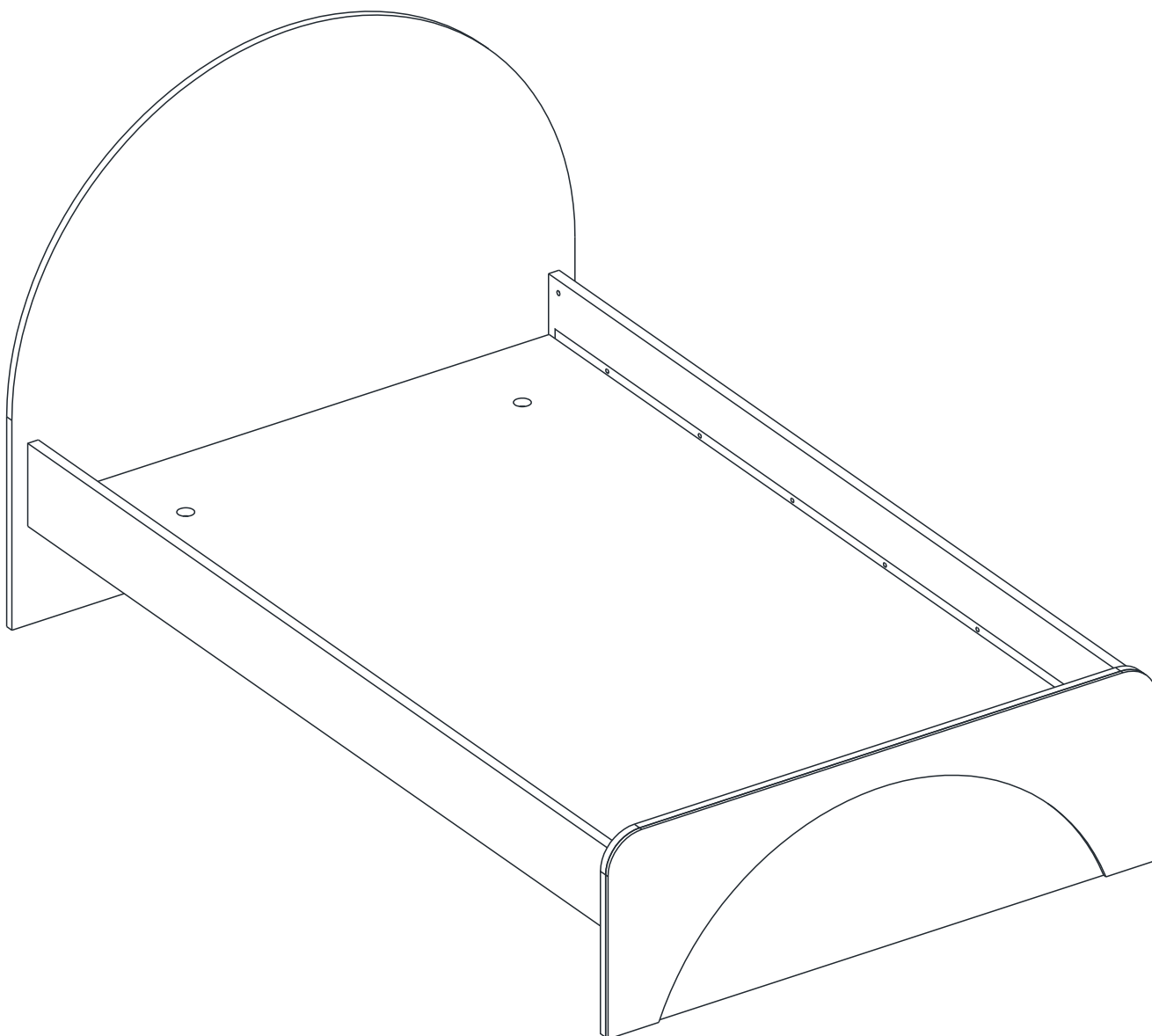

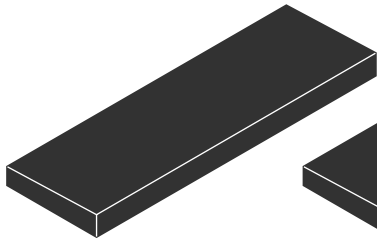

5 / 1

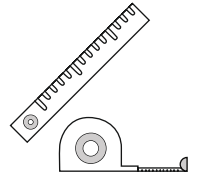
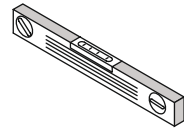
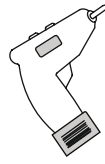
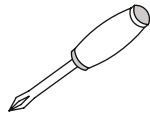
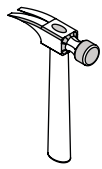
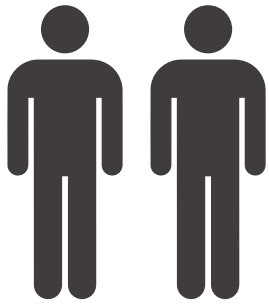
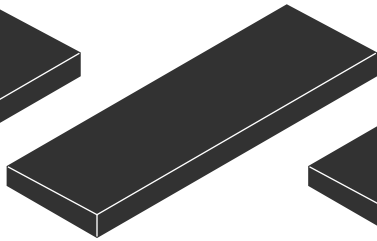

5 / 2

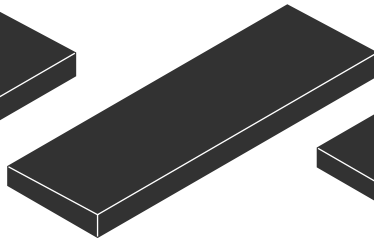

5 / 3

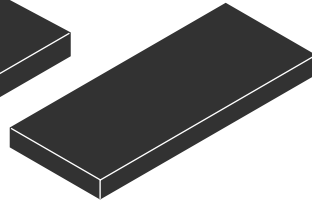

5 / 4

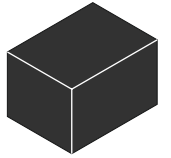

5 / 5

5 / 5

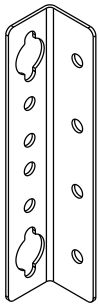

150 10 05 398 x 4

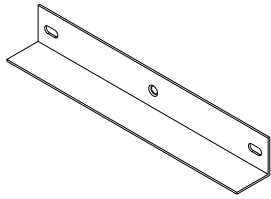

150 10 05 1164 x 2

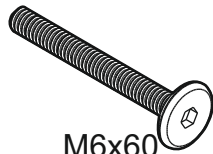

M6x60

150 10 05 229 x 4



M6x15

150 10 05 186 x 12

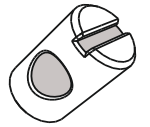

150 10 05 202 x 4



150 10 05 294 x 4

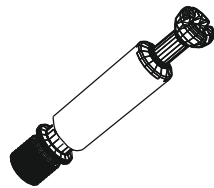

150 10 05 362 x 4



150 10 05 364 x 8



150 10 05 307 x 4

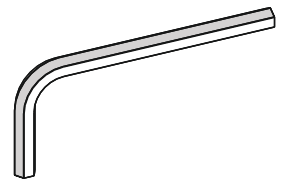

150 10 05 383 x 1



3,5x16

150 10 05 237 x 16

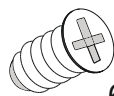

6x13

150 10 05 152 x 6



5 / 1

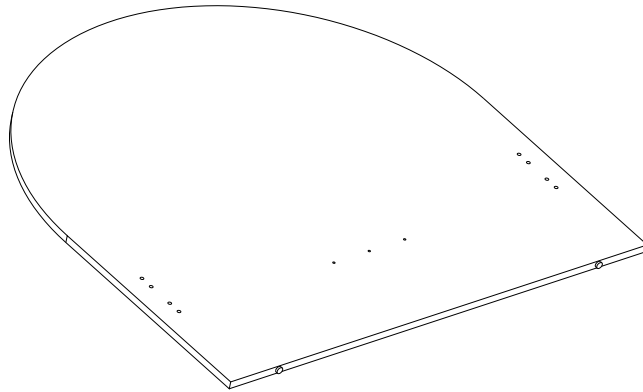

151 01 02 22222 001 x 1

---

5 / 2

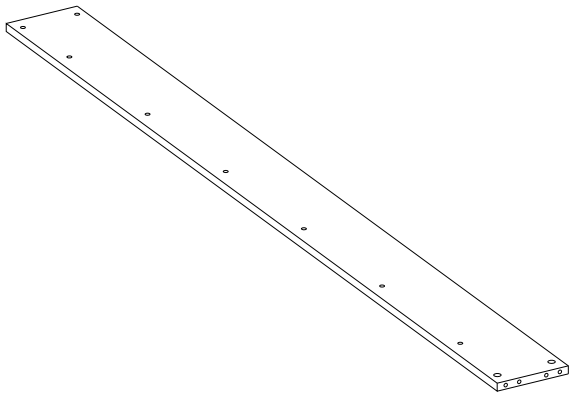

151 01 02 22222 004 x 1

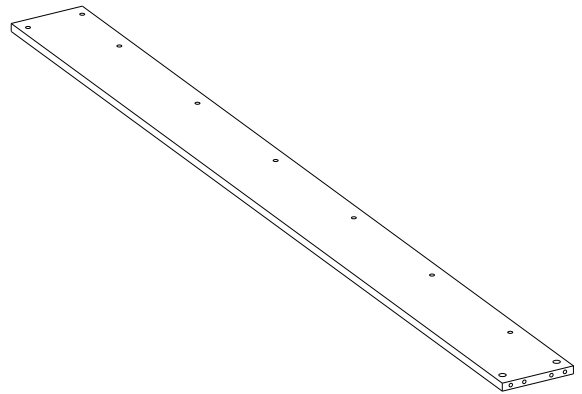

151 01 02 22222 003 x 1

---

5 / 3

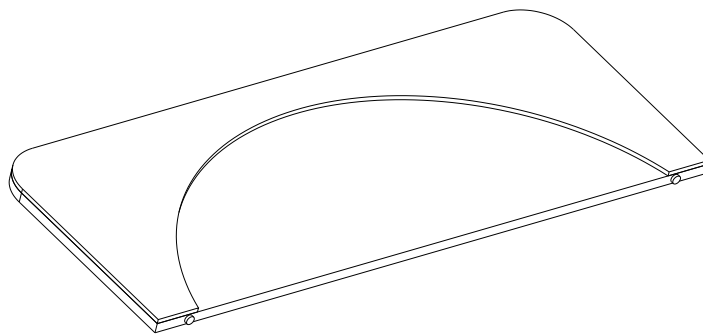

151 01 02 22222 002 x 1

---

5 / 4

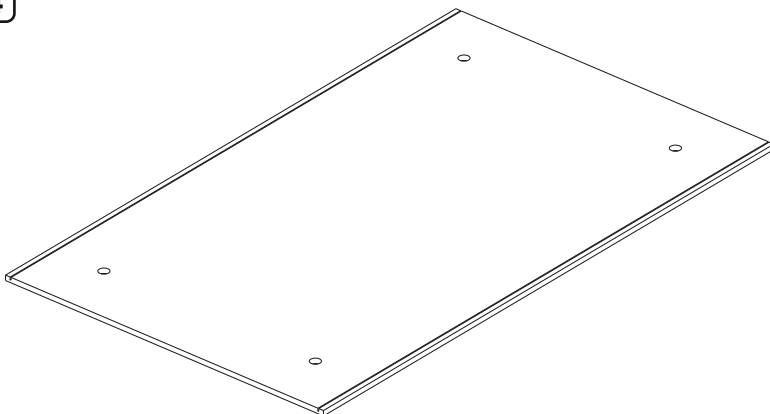

151 01 02 22222 006 x 1

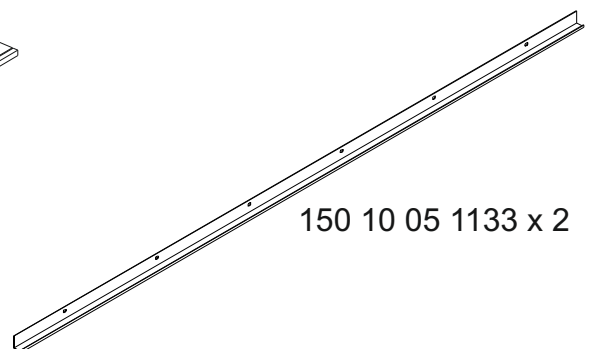

150 10 05 1133 x 2

1

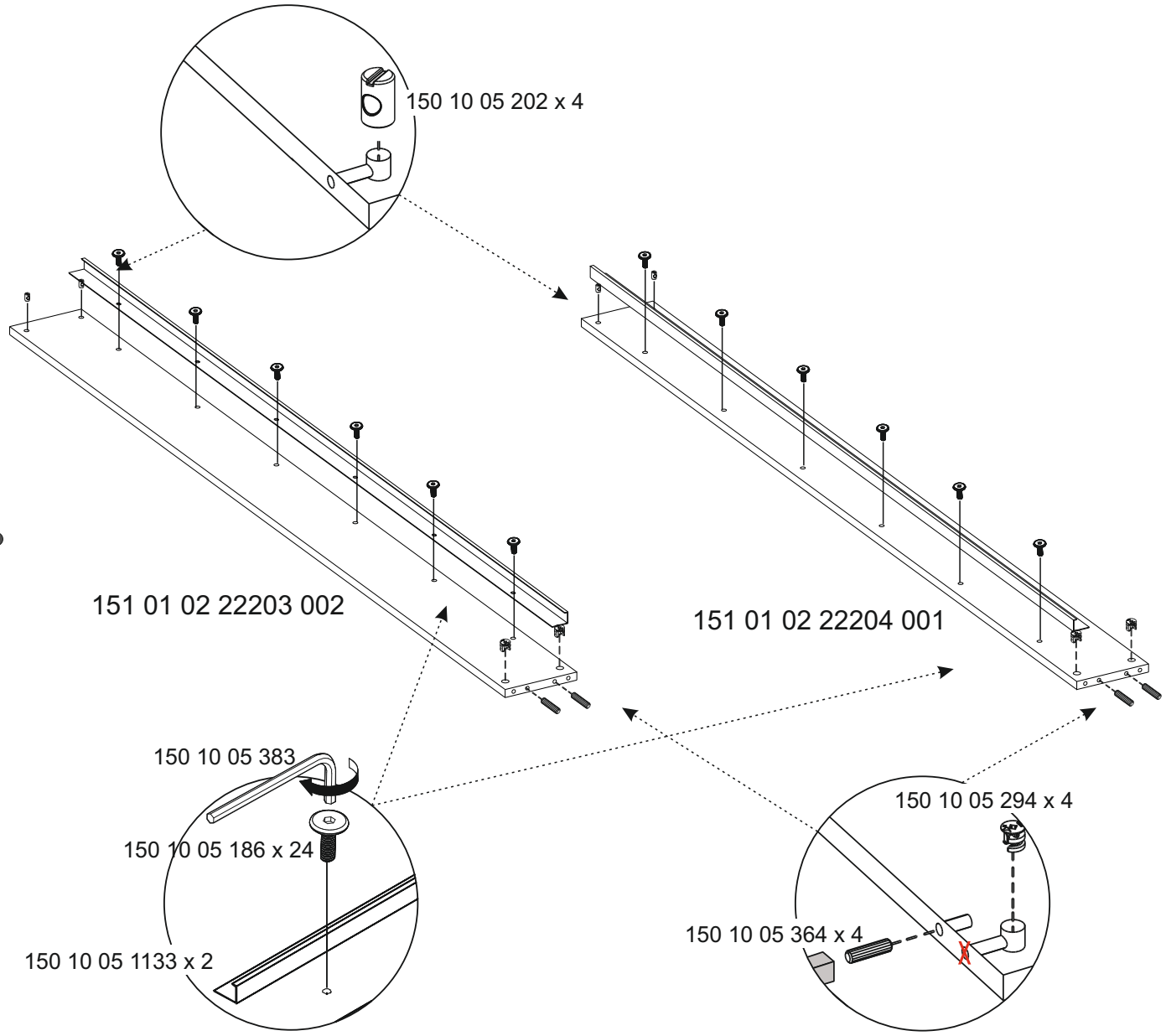

2

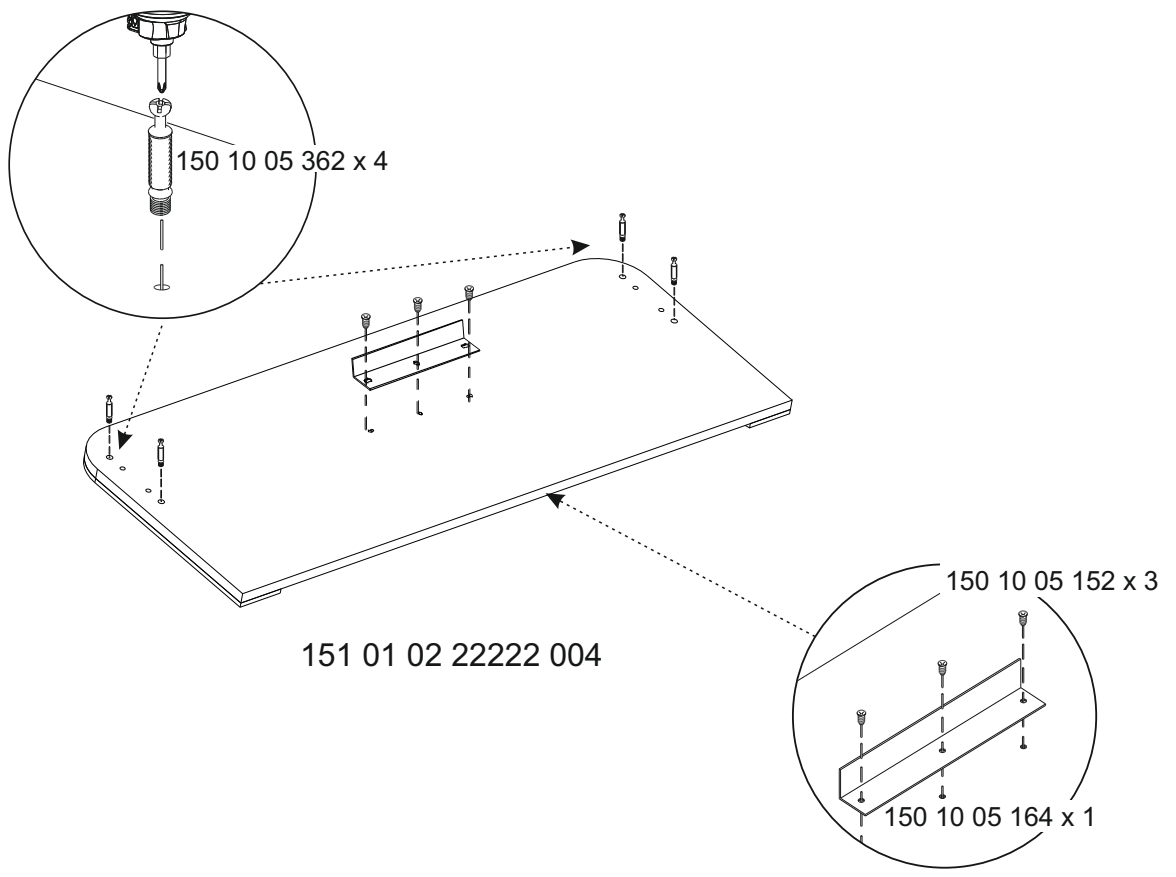

3

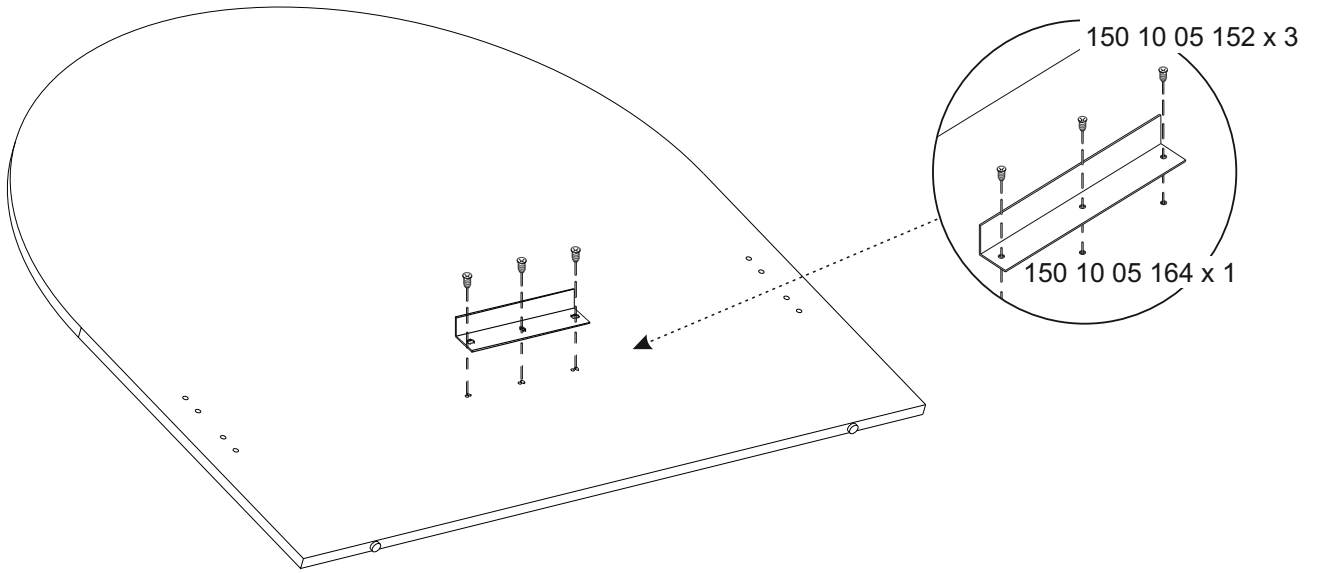

151 01 02 22222 001

4

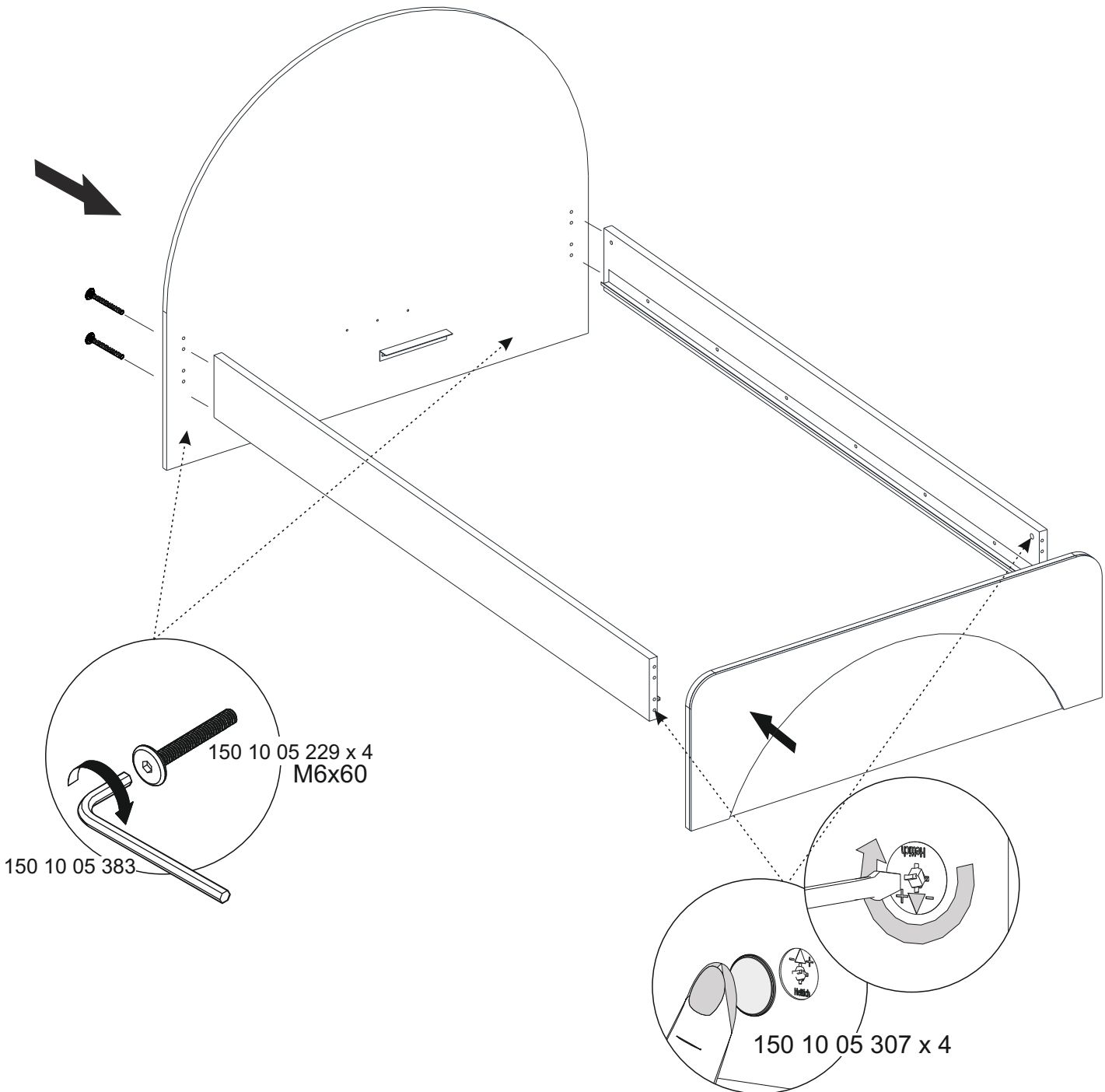

5

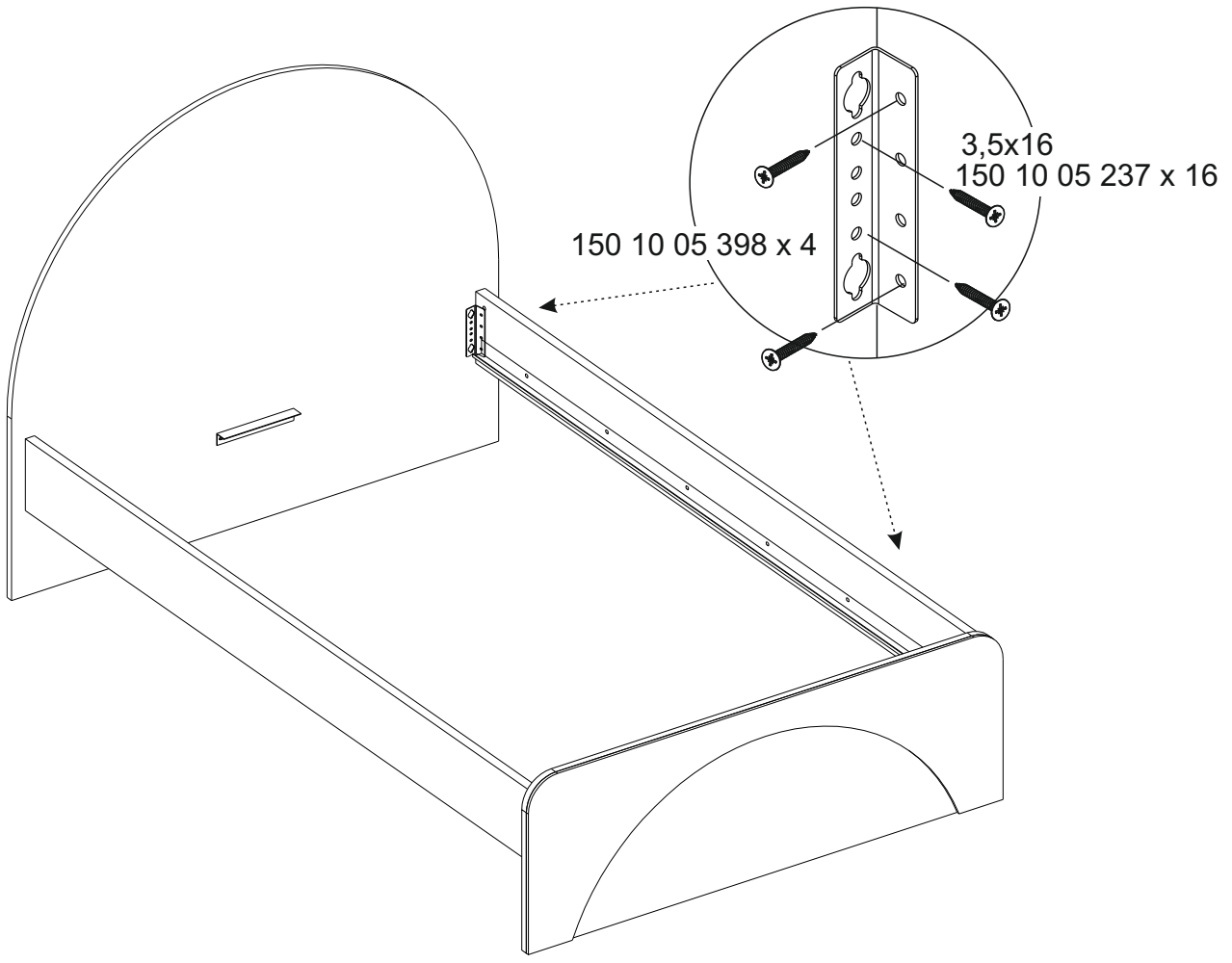

6

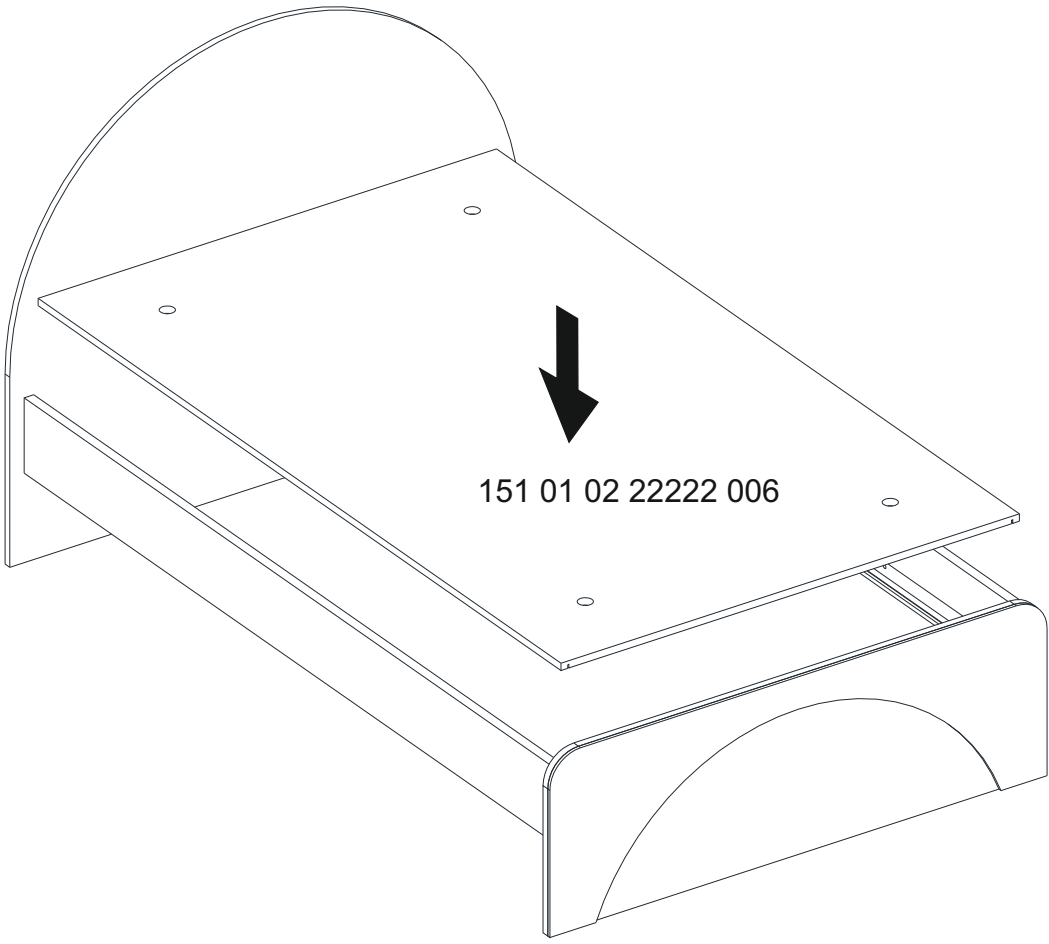

## ENGLISH

Important information

Read carefully

Keep this information for further reference

## WARNING

**Serious or fatal crushing injuries can occur from furniture tip-over. To prevent this furniture from tipping over it must be permanently fixed to the wall with the included wall attachment devices.**

Fixing devices for the wall are not included since different wall materials require different types of fixing devices. Use fixing devices suitable for the walls in your home. For advice on suitable fixing systems, contact your local specialized dealer.

## DEUTSCH

Wichtige Information

Sorgfältig lesen

Diese Information aufbewahren

## ACHTUNG

**Wenn Möbelstücke umkippen, können ernste oder lebensgefährliche Verletzungen durch Einklemmen die Folge sein. Um zu verhindern, dass dieses Möbelstück umkippt, muss es mit der beige packten Vorrichtung zur Wandbefestigung fest an der Wand verankert werden.**

Beschläge für die Wandbefestigung sind nicht beige packt, da sie von der Beschaffenheit der Wand und des Untergrundmaterials abhängig sind. Befestigungsbeschläge benutzen, die für die heimischen Wände geeignet sind. Bei diesbezüglichen Fragen den örtlichen Fachhandel zu Rate ziehen.

## 中文

重要信息

请仔细阅读

保留该信息，以备日后参考

警告

家具倾倒可能导致严重或致命伤害。必须使用产品包装内的墙壁安装件将家具固定在墙上，防止倾倒。

不同材质的墙壁需使用不同类型的固定装置，因此包装内不含墙壁固定装置。请选用适合家中墙壁的固定装置。欲获取适用固定系统的相关建议，请联系当地的专业零售商。

## FRANÇAIS

Information importante

À lire attentivement.

Conserver ces informations pour une utilisation ultérieure.

ATTENTION

**Risque de blessure grave ou mortelle en cas de basculement du meuble.**

Pour éviter que le meuble

**ne bascule, il faut le fixer au mur de façon permanente à l'aide des pièces pour fixation incluses.**

Les vis ne sont pas incluses car leur choix dépend du matériau du mur sur lequel est fixé le meuble. Utilisez des vis adaptées au matériau du mur. Pour obtenir des conseils sur les vis à utiliser, adressez-vous à un vendeur spécialisé.

يارانه نتيجة مميتة أو بالغة صاباتا تحدث قد

دائمًا باستخدام نطالها مع

لأن ذلك متضمنة غير طالحا على التثبيت أدوات. المرفقة يأنطالها يتالتشب أدوات

هناك

تتطلب وهي طالحا من مختلفة أنواع .

أنواع

مختص في على اتصل، المناسب التثبيت

## РУССКИЙ

Важная информация

Внимательно прочитайте.

Сохраните эту информацию для справок в дальнейшем

## ВНИМАНИЕ !

**Опрокидывание мебели может стать причиной получения серьезных травм или даже привести к смерти. Чтобы предотвратить опрокидывание, необходимо обеспечить стационарное крепление мебели к стене с помощью прилагающихся крепежных аксессуаров.**

Материалы стен различаются, поэтому крепежные средства не прилагаются. Используйте крепежные средства, подходящие для материала стен в вашем доме. Для выбора подходящих крепежных средств обратитесь в специализированный магазин.

## TÜRKÇE

Önemli bilgi

Dikkatli okuyunuz

Bu kılavuzu ileride gerekebileceği için saklayınız

## UYARI

**Mobilyanın devrilmesi sonucu ölümcül veya ciddi yaralanmalar meydana gelebilir. Devrilme riskini önlemek için mobilyanın, ürüne dahil olan aparat ile duvara sabitlenmesi gerekmektedir.**

Duvar yapı malzemeleri farklılık gösterebileceğinden, mobilyanın duvara sabitlenmesi için gereken bağlantı parçaları ürüne dahil değildir. Evinizin duvar yapı malzemesine uygun bağlantı parçaları seçiniz. Duvar yapı malzemenize uygun bağlantı parçaları satın almak için en yakın yapı marketya da bir nalbur dükkanından bilgi alabilirsiniz.